

VAC KING



**20V 20L WET/DRY CORDLESS
VACUUM CLEANER**

MODEL NO: CVAC18V20

PART NO: 6471104

OPERATING & MAINTENANCE INSTRUCTIONS

UK
CA | CE



ORIGINAL INSTRUCTIONS

DL0124

INTRODUCTION

Thank you for selecting this Vac King 20 Volt Vacuum Cleaner, which will provide you with a clean and safe working environment.

Before attempting to operate the cleaner, it is essential that you read this manual thoroughly and carefully follow all instructions given. In doing so you will ensure the safety of yourself and that of others around you, and you can also look forward to the cleaner giving you long and satisfactory service.

SPECIFICATION

MODEL	CVAC18V20
Part No	6471104
Weight	4 kg
Dimensions (D x W x H)	330mm x 330mm x 520mm
Drum Capacity	20 Litres
Water Capacity	15 Litres
Dust Capacity	13 Litres
Hose Dimensions (Length x Diameter)	1500mm x 32mm
Max Airflow	1.2 m ³ /min
Duty Cycle	S1 (continuous)
Battery Charger Power Supply	230 V/50Hz/1ph
Battery Voltage	20V
Battery Charging Time	Approx. 100 mins.
Discharge (Usage) Time	Approx. 21 mins
Motor Rated Input	180W
Vacuum IP Rating	IPX4
Operating Temperature	0 - 30°C

Please note that the details and specifications contained herein, are correct at the time of going to print. However, CLARKE International reserve the right to change specifications at any time without prior notice.

SAFETY PRECAUTIONS

GENERAL SAFETY

1. Prior to use, all users should become familiar with this instruction booklet.
2. This cleaner can be used by children aged from 8 years and above and persons with reduced physical, sensory or mental capabilities or lack of experience and knowledge if they have been given supervision or instruction concerning the use of the cleaner in a safe way and understand the hazards involved.
3. **DO NOT** let children play with this cleaner, supervise children using or maintaining the cleaner.
4. **AVOID** operating in the presence of flammable liquids or gases. The motor may produce sparks during operation. **DO NOT** use in enclosed areas where flammable, explosive or toxic vapours are given off.
5. **ALWAYS** stay alert, watch what you are doing and use common sense when operating. **DO NOT** use the machine while you are tired or under the influence of medication, drugs or alcohol. A moment of inattention can result in personal injury.
6. **NEVER** over-reach. Keep your proper footing and balance at all times to enable better control of the machine in unexpected situations. Take extra care when cleaning stairs.
7. **DO NOT** block the cleaners openings or hinder air flow. Keep openings free of objects including dust, lint, clothing and all body parts.

GENERAL MACHINE USE AND CARE

8. **ALWAYS** maintain the cleaner with care and keep it clean for best / safest performance.
9. **NEVER** use this cleaner if any part is damaged. Have it inspected and repaired by your CLARKE dealer. **DO NOT** use if the battery or the cleaner itself, is in poor condition..
10. **ALWAYS** take care when a long hose is required in the work area as it presents a trip hazard. Tidy the hose away when the job is finished.
11. **NEVER** pick up burning cigarettes or other hot or smoking substances.
12. **NEVER** abuse the cleaner by standing on it.
13. **ALWAYS** transport the cleaner by lifting it by the handle.
14. When not in use, turn off by the On/Off switch on top of the cleaner and remove the battery.

15. **DO NOT** change filters or carry out any cleaning or servicing, without first removing the battery.
16. Keep the external surfaces clean. **AVOID** impact damage and **DO NOT** allow the cleaner, charger or battery to come into contact with abrasive or corrosive materials.
17. **DO NOT** use solvents, thinners or alcohol to clean the cleaner, charger or battery, as these chemicals will damage the finish. With the cleaners battery unplugged from the battery compartment, use a dry cloth to wipe over the plastic casing.
18. When not in use the cleaner and battery should be stored in a secure, dry place, out of the reach of children. **DO NOT** leave it exposed to the elements and avoid direct sunlight, direct heat, rain/moisture etc.
19. Only use parts and accessories recommended in this manual. The use of unauthorised accessories or attachments may result in personal injury or damage to the machine.
20. **DO NOT** attempt to repair or modify the cleaner charger or battery. **DO NOT** attempt any electrical repair yourself. Consult a qualified electrician or the CLARKE Service Department on 020 8988 7400.

BATTERY SAFETY

1. Only use batteries and charger supplied with the cleaner.
2. If the battery or charger are damaged in anyway, **DO NOT** attempt to repair them. They should be replaced and the damaged item should be disposed of in accordance with local regulations.
3. **DO NOT** incinerate the batteries or expose to high temperatures, as they may explode.
4. Liquid ejected from the battery may cause irritation or burns. Leaks from the battery cells can occur under extreme conditions. **DO NOT** touch any liquid that leaks from the battery. If any liquid gets on the skin, wash immediately with soap and water. If liquid gets into the eyes, flush them immediately with water for a minimum of 10 minutes and seek medical attention. wear gloves to handle the battery and dispose of immediately in accordance with local regulations.
5. Keep the battery away from all metal objects such as paper clips, coins, keys, nails or screws. Shorting the battery terminals increases the risk of fire or burns.

INVENTORY OF COMPONENTS

No	Description	No	Description
1	Handle with Airflow Adjustment	9	Plastic Hose
2	Metal Telescopic Tube	10	Wet & Dry Brush
3	Suction Port	11	Washable Sponge Filter
4.	Wheels & Detachable Base	12	Washable HEPA Filter
5	Stainless Steel Tank	13	Long Crevice Nozzle
6	Blower Port	14	Round Brush Nozzle
7	Power Switch	15	4Ah Battery
8	Battery Compartment	16	Battery Charger



BATTERY CHARGER ELECTRICAL CONNECTIONS



WARNING! READ THESE ELECTRICAL SAFETY INSTRUCTIONS THOROUGHLY BEFORE CONNECTING THE PRODUCT TO THE MAINS SUPPLY.

Before switching the battery charger on, make sure that the voltage of your electricity supply is the same as that indicated on the rating plate. This battery charger is designed to operate on 230VAC 50Hz. Connecting it to any other power source may cause damage.

This battery charger may be fitted with a non-rewireable plug. If it is necessary to change the fuse in the plug, the fuse cover must be refitted. If the fuse cover becomes lost or damaged, the plug must not be used until a suitable replacement is obtained.

If the plug has to be changed because it is not suitable for your socket, or due to damage, it should be cut off and a replacement fitted, following the wiring instructions shown below. The old plug must be disposed of safely, as insertion into a mains socket could cause an electrical hazard.

Plug must be BS1363/A approved.

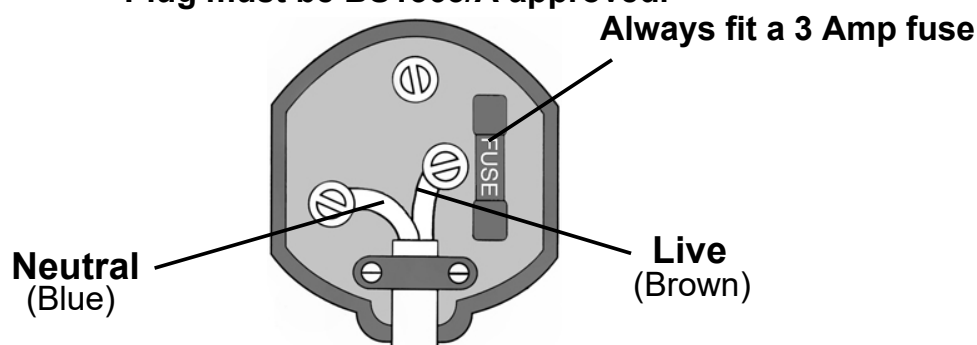

Ensure that the outer sheath of the cable is firmly held by the clamp

If in any doubt, consult a qualified electrician. **DO NOT** attempt any repairs yourself.

ENVIRONMENTAL PROTECTION



Li-ion

By purchasing this product, the customer is taking on the obligation to deal with its safe disposal in accordance with the Waste Electrical and Electronic Equipment regulations (WEEE).

In effect, this means that this product must not be disposed of with general household waste. It must be disposed of according to the laws governing Waste Electrical and Electronic Equipment (WEEE) at a recognised disposal facility.

PREPARATION FOR USE



WARNING: BEFORE USING THE VACUUM CLEANER, MAKE SURE THAT YOU HAVE READ AND UNDERSTOOD THE SAFETY INSTRUCTIONS

UNPACKING & ASSEMBLY

With the vacuum cleaner removed from the packaging, remove the components from within the tank. Lay them out and check for shortages and that no damage was suffered in transit.

FITTING THE WHEELS

1. Press the 4 wheels into the holes on each corner of the detachable base unit as shown.



FITTING DETACHABLE BASE

1. Fit the base to the bottom of the tank, as shown.



2. Press the 4 connecting tabs inwards, as shown.



ASSEMBLING THE HOSE

1. Push the plastic hose end into the suction port, making sure the 2 tabs on the hose end align with the grooves in the suction port.
2. Twist the hose clockwise to lock in place.

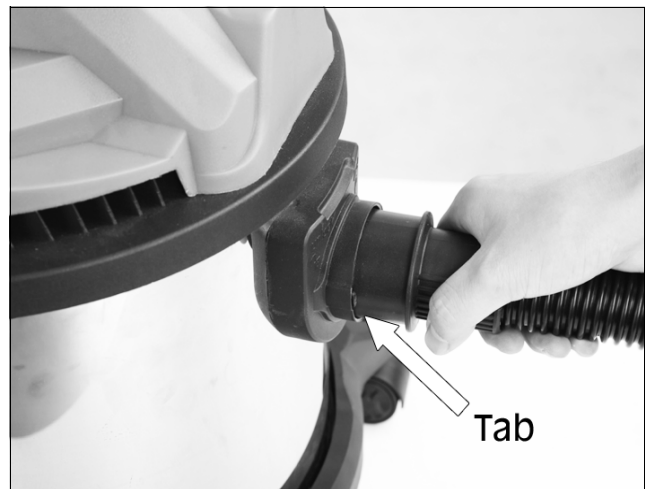

3. Insert the plastic hose handle into the wider end of the metal telescopic tube and push in until it is a tight fit.

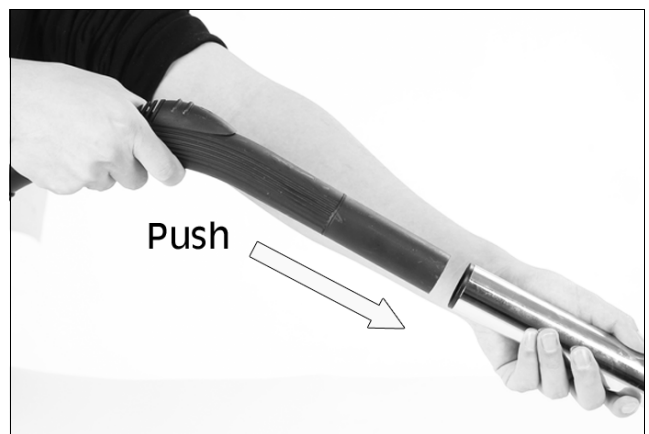

4. Adjust the telescopic tube to the required length by pushing the release button forward and sliding the bottom tube out.

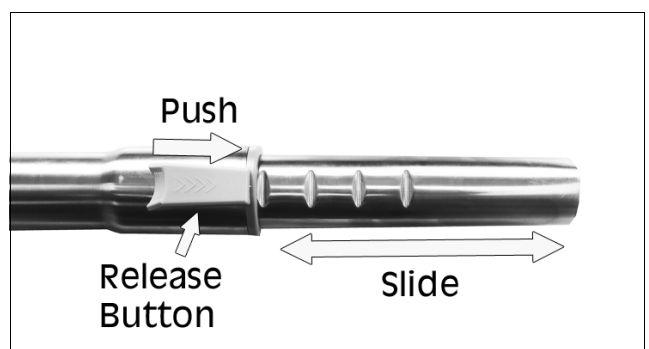

5. Insert the telescopic tube into the required brush or nozzle and push in until it is a tight fit, wet & dry brush shown

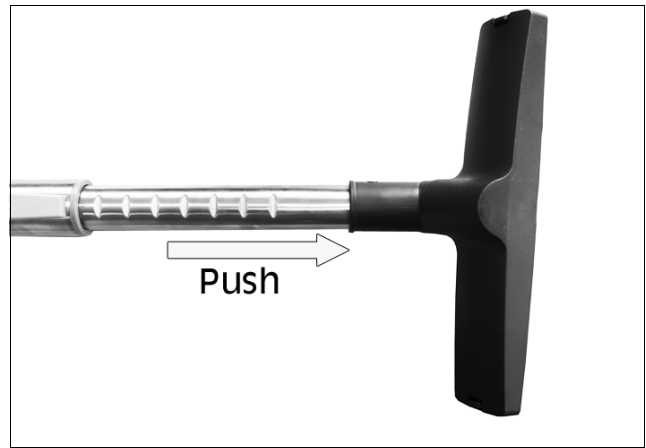

FITTING/CHANGING THE FILTERS

Filters are essential to ensure that dust or foreign matter does not enter the motor compartment which would reduce motor efficiency and eventually cause serious damage.

HEPA FILTER FOR DRY CLEANING

1. Fit the HEPA filter over the top of the safety flotation valve housing, as shown.
2. Line up the 3 tabs on the filter with the 3 grooves in the motor unit and turn the filter clockwise to lock in place.

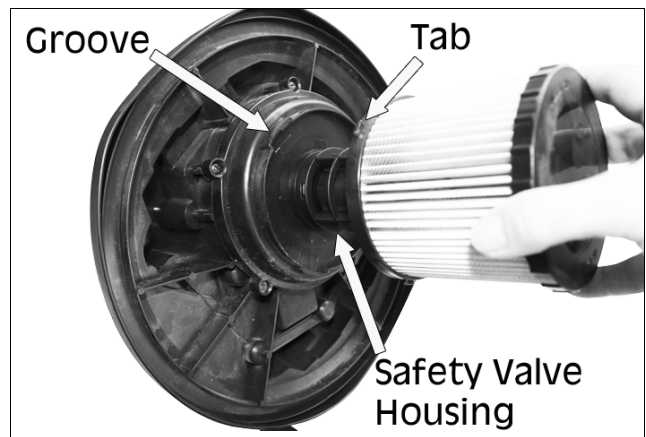

SPONGE FILTER FOR WET CLEANING

1. Place the sponge filter over the safety flotation valve housing, making sure it covers the whole housing, as shown.

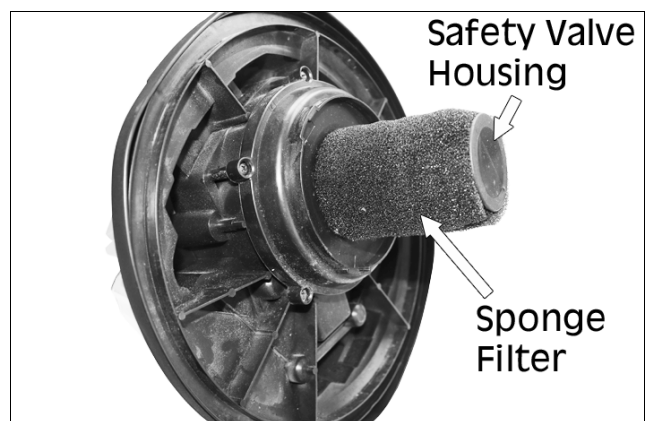

BATTERY INSTALLATION

1. Lift the battery compartment lid.
2. Slide the battery into the compartment, with the release clip on the outside.
3. Before use, make sure the compartment lid is firmly clipped down in place.



4. To check how much power is in the battery, press the power indicator button on the end of the battery. The following lights will indicate how much power is in the battery.

- 1 Light: 33% power
- 2 Lights: 66% power
- 3 Lights: 100% power



OPERATION

SUCTION

1. Before operating the cleaner, make sure that the appropriate filter is fitted correctly (see pages 8-9) for the job in hand, as follows:
 - Dry Vacuum Cleaning, use the HEPA filter.
 - Wet Vacuum Cleaning, use the sponge filter.
 - Mixture of material and liquid, use both filters, fitting the sponge filter first then the HEPA filter over the top.
2. Choose the appropriate brush/nozzle and fit to the end of the metal tube (see page 8)

3. Fix the hose to the suction port (see page 7)
4. Make sure that the motor housing is seated on top of the tank and the clips are locked in place.

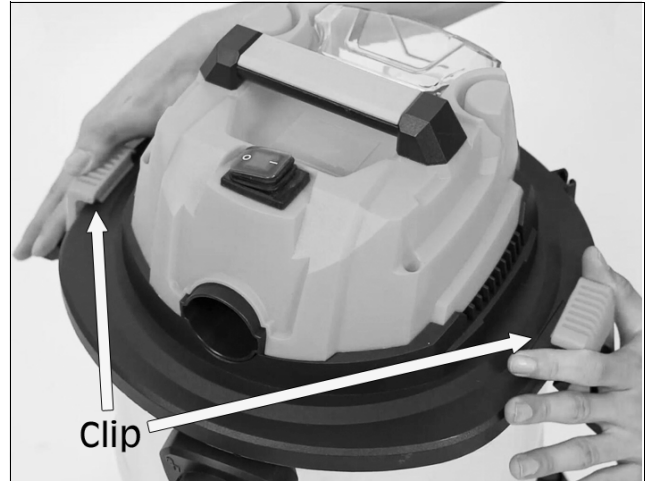

5. Switch on and start work.

NOTE: The cleaner should be positioned on a firm, level surface, specially when using for wet cleaning.

NOTE: The tank will hold approximately 14 litres of liquid before the safety flotation valve shuts off the vacuum flow. This can be recognised by a change in the noise of the motor. Once this happens, switch off the cleaner and empty the tank of all liquid.

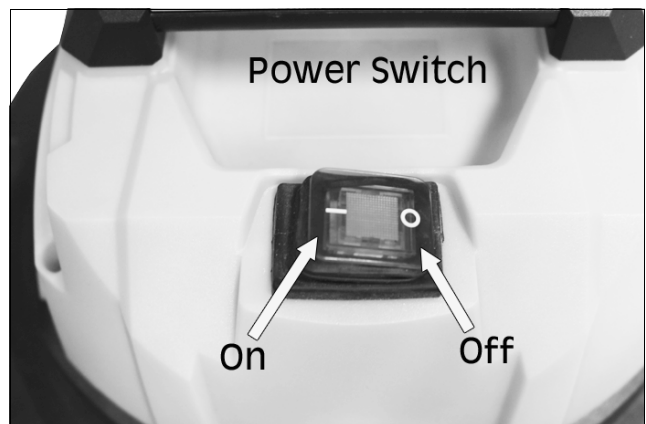

BLOWER

This vacuum has a blower function, as follows:

1. Before starting the blower function, make sure the tank is empty of all liquid and dirt.
2. Push the plastic hose end into the blower port, making sure the 2 tabs on the hose end align with the grooves in the blower port.
3. Twist the hose clockwise to lock in place.

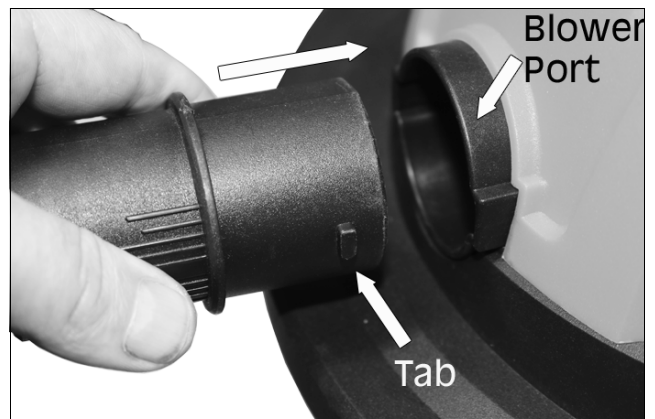

4. Insert the telescopic tube into the crevice nozzle and push in until it is a tight fit, this will give you a stronger airflow.
5. Switch on and start work.

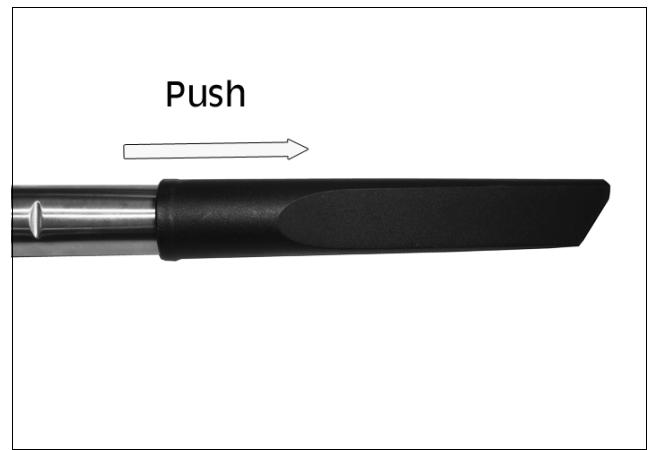

MAINTENANCE



WARNING: TAKE OUT THE BATTERY BEFORE DOING ANY MAINTENANCE WORK. IF PROPER CARE IS TAKEN TO MAINTAIN YOUR CLEANER, MOTOR MAINTENANCE IS UNNECESSARY.

CLEANING YOUR FILTERS

1. Take the filter off the cleaner (see pages 8-9)
2. Gently wash the filters (avoid brushing them) with water only, at 40c max.
3. Dry the filters for at least 24 hours before reusing them.

CLEANING YOUR ACCESSORIES

1. Wash the hose, tube and brush/nozzles regularly to reduce build up of dirt, using water at a 40c max.
2. Shake the water off from inside, and make sure that they dry for 24 hours before reuse.

CLEANING THE TANK

1. Clean out any liquid from inside the tank.
2. Wipe down the inside with a duster cloth.

TROUBLESHOOTING

Symptom	Possible Cause	Corrective action
Suction weakens	Clogged filter	Clean dirt from filter. If condition continues, change filter.
	Air leak	Check the connection of all the accessories (hose, brush/nozzle, etc). Check that clips are fastened properly.
	Obstruction in hose or brush/nozzle	Check hose and brush/nozzle for obstructions and remove if present.
	Saturated filter	Replace saturated filter.
Dust leakage	Filter is not fitted well	Check if the filter is fitted in the right position.
Cleaner doesn't work	Battery is not well charged	Check if there is any power left in the battery; or charge battery.
	Motor breakdown	Send the cleaner to your CLARKE dealer for repair.

GUARANTEE

This CLARKE product is guaranteed against faulty manufacture for a period of 12 months from the date of purchase. Please keep your receipt as proof of purchase.

This guarantee is invalid if the product is found to have been abused or tampered with in any way, or not used for its intended purpose.

Faulty goods should be returned to their place of purchase, no product can be returned to us without prior permission.

This guarantee does not effect your statutory rights.

PARTS LIST

1	Handle Cover	15	Safety Flotation Valve
2	Fixed Handle	16	Bracket
3	Battery Compartment Cover	17	HEPA Filter
4	Power Switch	18	Wheel
5	Top Cover	19	Base
6	Motor Top Cover	20	Stainless Steel Tank
7	Battery Platform	21	Suction Mouth
8	Battery Connector	22	Clip
9	Barrel Cap	23	Metal Telescopic Tube
10	Motor Top Seal Ring	24	Round Brush
11	Motor	25	Crevice Nozzle
12	Motor Bottom Seal Ring	26	Wet & Dry Floor Brush
13	Motor Cover Seal	27	Sponge Filter
14	Motor Base	28	Plastic Hose

COMPONENT PARTS

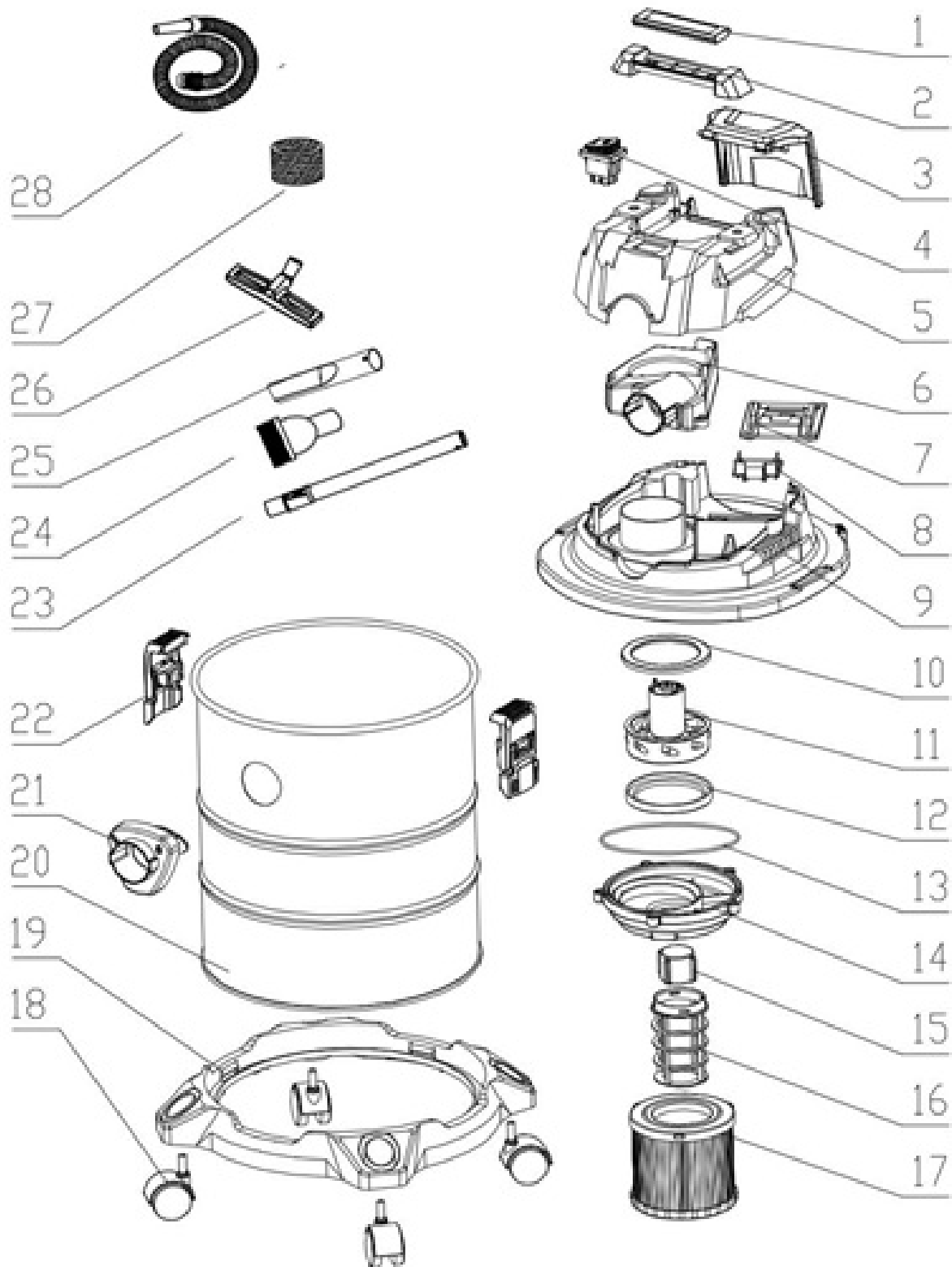

DECLARATION OF CONFORMITY

**UK
CA**

**Clarke[®]
INTERNATIONAL**
Hemnal Street, Epping, Essex, CM16 4LG

DECLARATION OF CONFORMITY

This is an important document and should be retained.

We hereby declare that this product(s) complies with the following legislation:

The Batteries and Accumulators (Placing on the Market) Regulations 2008
The Electromagnetic Compatibility Regulations 2016
The Electrical Equipment (Safety) Regulations 2016
The Restriction of the Use of Certain Hazardous Substances in Electrical and Electronic Equipment Regulations 2012

The following standards have been applied to the product(s):

EN 60335-1:2012+A11:2014+A13:2017+A1:2019+A14:2019+A2:2019, EN 60335-2-2:2010+A11:2012+A1:2013, IEC 62321-4:2013+AMD1:2017 CSV, EN IEC 61000-3-2:2019/A1:2021, IEC 62321-3-1:2013, IEC 62321-8:2017, EN 61000-3-3:2013/A2:2021, EN IEC 55014-1:2021, EN IEC 55014-2:2021, EN 62233:2008, IEC 62321-1:2013, IEC 62321-7-1:2015, IEC 62321-7-2:2017, IEC 62321-5:2013, IEC 62321-6:2015, ISO 17075:2017

The technical documentation required to demonstrate that the product(s) meet(s) the requirement(s) of the aforementioned legislation has been compiled and is available for inspection by the relevant enforcement authorities.

The UKCA mark was first applied in: 2024

Product Description: Vacuum Cleaner
Model Number(s): CVAC18V20
Serial/Batch Number: Refer to product/packaging label
Date of Issue: 10/01/2024

Signed: 
J.A. Clarke
Director

CVAC18V20 UKCA Clarke DOC 011024 Page 1 of 1

CE

**Clarke[®]
INTERNATIONAL**
Fitzwilliam Hall, Fitzwilliam Place, Dublin 2

DECLARATION OF CONFORMITY

This is an important document and should be retained.

We hereby declare that this product(s) complies with the following legislation:

2006/66/EC Battery Directive
2014/30/EU Electromagnetic Compatibility Directive
2014/35/EU Low Voltage Directive
2011/65/EU Restriction of Hazardous Substances (RoHS) Directive

The following standards have been applied to the product(s):

EN 60335-1:2012+A11:2014+A13:2017+A1:2019+A14:2019+A2:2019, EN 60335-2-2:2010+A11:2012+A1:2013, IEC 62321-4:2013+AMD1:2017 CSV, EN IEC 61000-3-2:2019/A1:2021, IEC 62321-3-1:2013, IEC 62321-8:2017, EN 61000-3-3:2013/A2:2021, EN IEC 55014-1:2021, EN IEC 55014-2:2021, EN 62233:2008, IEC 62321-1:2013, IEC 62321-7-1:2015, IEC 62321-7-2:2017, IEC 62321-5:2013, IEC 62321-6:2015, ISO 17075:2017

The technical documentation required to demonstrate that the product(s) meet(s) the requirement(s) of the aforementioned legislation has been compiled and is available for inspection by the relevant enforcement authorities.

The CE mark was first applied in: 2024

Product Description: Vacuum Cleaner
Model Number(s): CVAC18V20
Serial/Batch Number: Refer to product/packaging label
Date of Issue: 10/01/2024

Signed: 
J.A. Clarke
Director

CVAC18V20 CE Clarke DOC 011024 Page 1 of 1

A SELECTION FROM THE VAST RANGE OF



Clarke[®]

QUALITY PRODUCTS

AIR COMPRESSORS

From DIY to industrial, Plus air tools, spray guns and accessories.

GENERATORS

Prime duty or emergency standby for business, home and leisure.

POWER WASHERS

Hot and cold, electric and engine driven - we have what you need

WELDERS

Mig, Arc, Tig and Spot. From DIY to auto/industrial.

METALWORKING

Drills, grinders and saws for DIY and professional use.

WOODWORKING

Saws, sanders, lathes, mortisers and dust extraction.

HYDRAULICS

Cranes, body repair kits, transmission jacks for all types of workshop use.

WATER PUMPS

Submersible, electric and engine driven for DIY, agriculture and industry.

POWER TOOLS

Angle grinders, cordless drill sets, saws and sanders.

STARTERS/CHARGERS

All sizes for car and commercial use.

